

**Title:**

The fire resistance performance of two single leaf single acting doorsets with glazing, when tested in accordance with BS 476: Parts 20 and 22: 1987

**WF Report No:**

403484 Rev A



**Prepared for:**

**Vistamatic Ltd**

51-55 Fowler Road  
Hainault Industrial Estate  
Hainault  
Essex  
IG6 3XE

**Test date:**

14<sup>th</sup> August 2018



1762

This details of the test report WF 403484 are held on file by Warringtonfire. The original report and any previous revisions are replaced by this revised report. WF 403484 Revision A is a revision to that issued as WF 403484 and dated 06/12/2018.

## Contents

	Page No
Summary of Performance .....	3
1 Introduction.....	4
2 Specification .....	4
2.1 Door Leaf .....	4
2.2 Door Perimeter Gaps .....	4
2.3 Closer Forces.....	4
3 Description of Construction (Refers to Figures 1 to 4 of the Appendix) .....	5
4 Test Conditions .....	11
5 Test Results .....	12
5.1 Furnace Temperature Curve .....	12
5.2 Unexposed Face Temperature Curves.....	13
5.3 Door Distortion Data.....	16
5.4 Door Leaf to Frame Gaps.....	17
5.5 Observations.....	18
5.6 Times to Failure .....	19
6 Limitations .....	20
Photographs.....	21
Appendix – figures 1 to 4.....	25

## Summary of Performance

The following performance was achieved from the specimens tested. Full details of the testing and specimens construction are described in the report.

<b>Results:</b>  <b>Fire resistance test in accordance with BS476: Part 20/22: 1987</b>	<b>Times to failure:</b>										
		<table border="1"> <thead> <tr> <th></th> <th>Doorset A</th> <th>Doorset B</th> </tr> </thead> <tbody> <tr> <td><b>Integrity</b></td> <td style="text-align: center;"><b>40 (forty) minutes*</b></td> <td style="text-align: center;"><b>40 (forty) minutes*</b></td> </tr> <tr> <td><b>Insulation</b></td> <td style="text-align: center;"><b>0 (zero) minutes **</b></td> <td style="text-align: center;"><b>0 (zero) minutes **</b></td> </tr> </tbody> </table>		Doorset A	Doorset B	<b>Integrity</b>	<b>40 (forty) minutes*</b>	<b>40 (forty) minutes*</b>	<b>Insulation</b>	<b>0 (zero) minutes **</b>	<b>0 (zero) minutes **</b>
		Doorset A	Doorset B								
<b>Integrity</b>	<b>40 (forty) minutes*</b>	<b>40 (forty) minutes*</b>									
<b>Insulation</b>	<b>0 (zero) minutes **</b>	<b>0 (zero) minutes **</b>									
<p>* No failure at the termination of the test.  ** In accordance with the Section 8.6.1 of BS 476: Part 22: 1987, the specimen has not been evaluated for insulation</p>											



### Summary of specimen:

**Two latched single leaf single acting doorsets with glazing, both hung opening in towards the furnace**

Leaf size – doorset A:  
 2100mm high x  
 1140mm wide x 54mm thick

Leaf size – doorset B:  
 2100mm high x  
 1140mm wide x 45mm thick

## 1 Introduction

The glazing units were manufactured and supplied for test by the client and delivered during August 2018.

Warringtonfire at the request of the sponsor constructed two timber doorsets to the sponsors specified construction details as follows:

Doorset A	Door blank Hardwood lippings Softwood door frame Intumescent materials Hardware Overhead closer Glazed aperture	Doorset B	Door blank Hardwood lippings Softwood door frame Intumescent materials Hardware Overhead closer Glazed aperture
-----------	---	-----------	---

Warringtonfire constructed a plasterboard clad timber stud supporting construction and installed the specimens into the wall.

## 2 Specification

Details of the specimens are shown in the Appendix.

### 2.1 Door leaf

The left doorset was designated doorset A and the leaf measured 2100mm high x 1140mm wide x 54mm thick. The right doorset was designated doorset B and the leaf measured 2100mm high x 1140mm wide x 45mm thick. Both doorsets were hung to open in towards the furnace. The results of this test were obtained from doorsets fitted with a latch that was engaged for the test.

### 2.2 Door perimeter gaps

The gaps between the edge of the door and frame were measured prior to test. A total of 24 readings were taken. The measurements (in mm) are given in Section 5.4 of this report.

### 2.3 Closer forces

Measured in accordance with FTSG Resolution No 63.

	Opening force (Nm)	Closing force (Nm)
Doorset A	33	23
Doorset B	31	22

### 3 Description of Construction (Refers to Figures 1 to 4 of the Appendix)

#### Leaf – doorset A (Manufactured from a Flamebreak 660 door blank)

		Species/type	Dimensions (mm)	Density (kg/m <sup>3</sup> )	Moisture (% w/w)	Key to figures
Stiles and rails		Details held on file by Warringtonfire	-	-	-	-
Core		Details held on file by Warringtonfire	-	-	-	-
Facings		Details held on file by Warringtonfire	-	-	6.3	-
Adhesive	Lippings	Titebond Polyurethane Liquid Glue	-	-	-	-
Lippings – vertical edges only		Sapele	8 thick	640*	7.2	1

\* Nominal density –TRADA Timber database

#### Leaf – doorset B (Manufactured from a Halspan Prima 30 door blank)

		Species/type	Dimensions (mm)	Density (kg/m <sup>3</sup> )	Moisture (% w/w)	Key to figures
Core		Details held on file by Warringtonfire	-	-	6.4	-
Adhesive	Lippings	Titebond Polyurethane Liquid Glue	-	-	-	-
Lippings – vertical edges only		Sapele	8 thick	640*	7.3	2

\* Nominal density –TRADA Timber database

## Door frame – both doorsets

	Species/type	Dimensions (mm)	Density (kg/m <sup>3</sup> )	Moisture (% w/w)	Key to figures
Head and jambs	European Redwood	70 wide x 32 thick	510*	9.7-9.9	3
Head to jamb jointing detail	Mortice and tenon – screwed	-	-	-	-
Doorset A - stop – planted (pinned)	European Redwood	12 high x 15 wide	510*	-	4
Doorset B - stop – planted (pinned)	European Redwood	12 high x 20 wide	510*	-	5
Frame to supporting construction fire stopping detail	Rock mineral fibre for full depth of frame capped intumescent mastic on the exposed face	Nominally 8.7-14.1 wide x 10 deep (mastic depth only, mineral fibre remains full depth of frame)	-	-	-
Frame to supporting construction fixing detail	4No. steel screws per jamb	5Ø x 80 long	-	-	-
Architrave	European Redwood	44 wide x 18 thick	510*	11.2	-
Threshold	Non combustible	-	-	-	-

\* Nominal density – TRADA Timber database

## Intumescent and sealing materials – doorset A

	Make/type	Size (mm)	Location	Key to figures
Door edges	None fitted	-	-	-
Frame reveal – head and jambs	Lorient Polyproducts Ltd LP2004 Type 617	20 x 4	Fitted centrally in the frame reveal	6
Glazing perimeter	Mann McGowan Pyroglaze 30	10 x 3	Fitted between the glass and bead on both faces	7
	Norseal acrylic intumescent mastic (Fire Wizard)	Nominally 3 thick	Fitted lining the glazing aperture between the Pyroglaze 30 intumescent	8

### Intumescent and sealing materials – doorset B

	Make/type	Size (mm)	Location	Key to figures
Door edges	None fitted	-	-	-
Frame reveal – hanging edge only	Lorient Polyproducts Ltd LP1504 Type 617	15 x 4	Fitted centrally in the frame reveal	9
Glazing perimeter	Mann McGowan Pyroglaze 30	10 x 3	Fitted between the glass and bead on both faces	10
	Norseal acrylic intumescent mastic (Fire Wizard)	Nominally 3 thick	Fitted lining the glazing aperture between the Pyroglaze 30 intumescent	11

### Intumescent interruptions and additional hardware protection – doorset A

	Make/type	Size (mm)	Location
Around hinge blade	Partially interrupted	-	Hinge blade partially interrupts the seal in the frame reveal leaving the 2mm continuous
Under hinge blades	Interdens	1 thick	Fitted under the hinge blade on frame and leaf
Encasing latch body	Interdens	1 thick	Fitted around the body of the latch
Under latch forend	Interdens	1 thick	Fitted under the latch forend
Around latch keep	Fully interrupted	-	Latch keep fully interrupts seal in frame reveal
Under latch keep	Interdens	1 thick	Fitted under the latch keep

### Intumescent interruptions and additional hardware protection – doorset B

	Make/type	Size (mm)	Location
Around hinge blade	Fully interrupted	-	Hinge blade fully interrupts the seal in the frame reveal
Under hinge blades	Interdens	1 thick	Fitted under the hinge blade on frame and leaf
Encasing latch body	Interdens	1 thick	Fitted around the body of the latch
Under latch forend	Interdens	1 thick	Fitted under the latch forend
Around latch keep	Fully interrupted	-	Latch keep fully interrupts seal in frame reveal
Under latch keep	Interdens	1 thick	Fitted under the latch keep

## Hardware – both doorsets

	Make/type	Size (mm)	Location	Key to figures
Hinges	3 No. Royde and Tucker H101 lift off type hinges	100 x 35 (blade size)	Fitted 150mm, 980mm and 1820mm from the head of the leaf	12
Closer	Rutland TS3204 overhead type closer	220 x 59 (footprint size)	Fitted on the exposed face of the leaf as per the manufacturer's instructions	13
Latch – disengaged	E*S tubular steel mortice latch	60 x 25 (forend size)	Latch nib fitted 1000mm from the threshold of the leaf	14
		65 x 24 (keep size)		
Furniture	Aluminium lever type handle	100 x 38 (footprint size)	Fitted appropriate to the latch	15



## Glazing – doorset A

	Make/type	Size (mm)	Location	Key to figures
Glass type – 31mm thick between glass blinds™ unit with magnetic adjustable privacy blinds between the glass layers	Pilkington Optiwhite Toughened Glass*	4 thick*	Fitted on the unexposed face, 290mm from the leaf head, 260mm from the closing edge of the leaf	16
	BGB magnetically operated internal blind – consisting of an aluminium frame and shutter assembly operated with a string pulley system*	12.5 thick*	Fitted between the outer layers of glass.	17
	Pilkington Pyrodur*	7 thick*	Fitted on the exposed face, 290mm from the leaf head, 260mm from the closing edge of the leaf	18
	Aluminium spacer*	20 thick*	Fitted between the outer layers of glass	19
Aperture size	-	1506 high x 606 wide	-	-
Glass size	-	1500 high x 600 wide	-	-
Sight size	-	1475 high x 575 wide	-	-
Expansion allowance	-	3mm all round		-
Double Glazed Unit Perimeter sealing	Hot Melt Butyl Sealant details held on file by Warringtonfire	-	-	-
Beading – doorset A	Sapele (nominal density 640kg/m <sup>3</sup> m.c. 8.4%)	20 high x 17 deep including a 9 x 9 bolection return and a 15° chamfer*	Fitted around the glazing aperture on both faces	20
Beading fixings	Steel Pins	60 long	Fitted at 50mm from corners at 150mm centres at 35° to the face of the glass	21

\* Stated by client, not verified by laboratory

## Glazing – doorset B

	Make/type	Size (mm)	Location	Key to figures
Glass type – 33mm thick between glass blinds™ unit with magnetic adjustable privacy blinds between the glass layers	Pilkington Optiwhite Toughened Glass*	6 thick*	Fitted on the unexposed face, 290mm from the leaf head, 260mm from the closing edge of the leaf	22
	BGB magnetically operated internal blind – consisting of an aluminium frame and shutter assembly operated with a string pulley system*	12.5 thick*	Fitted between the outer layers of glass.	23
	Pilkington Pyrodur*	7 thick*	Fitted on the exposed face, 290mm from the leaf head, 260mm from the closing edge of the leaf	24
	Aluminium spacer*	20* thick	Fitted between the outer layers of glass	25
Aperture size	-	1506 high x 606 wide	-	-
Glass size	-	1500 high x 600 wide	-	-
Sight size	-	1475 high x 575 wide	-	-
Expansion allowance	-	3mm all round	-	-
Double Glazed Unit Perimeter sealing	Hot Melt Butyl Sealant details held on file by Warringtonfire	-	-	-
Beading – doorset B	Sapele (nominal density 640kg/m <sup>3</sup> m.c. 7.9%)	20 high x 17 deep including a 9 x 9 bolection return and a 15° chamfer*	Fitted around the glazing aperture on both faces	26
Beading fixings	Steel Pins	60 long	Fitted at 50mm from corners at 150mm centres at 35° to the face of the glass	27

\* Stated by client, not verified by laboratory

## 4 Test Conditions

Where areas of the test specification are ambiguous or open to interpretation the Fire Test Study Group Resolutions No's 51, 63, 70, 71, 72 and 78 have been followed (further specific details are available on request). These Resolutions provide basis of common agreements between the fire test laboratories which are members of this Group.

The ambient temperature of the test area at commencement of test was 19°C.

After the first 5 minutes of the test, the furnace pressure was maintained such that it complied with the requirements of BS 476-20:1987 clause 3.2.2 (including allowance for transient occurrences in line with clause 12 (L)) at  $-4.25 \pm 2$  Pa with respect to atmosphere, at a point 0.5m from the notional floor level, equating to 0Pa at a point 1m above the notional floor level.

The furnace was controlled to follow the temperature/time relationship specified in BS 476 - 20: 1987 as closely as possible, using the average of nine thermocouples suitably distributed within the furnace. The temperatures recorded are shown graphically in Section 5.1.

The temperature of the unexposed face of both doorsets was monitored by means of five thermocouples fixed to the surface of the door leaf and three thermocouples attached to the frame, one at midheight on each jamb and one centrally located above the leaf on the frame head. Two additional thermocouples were fixed to the glass.

The thermocouple positions are shown in Figure 4 of the appendix. The average temperature of the door leaves and maximum temperature of the doorsets are shown graphically in Section 5.2.

## 5 Test results

The following data and observations were recorded during the test.

### 5.1 Furnace Temperature Curve

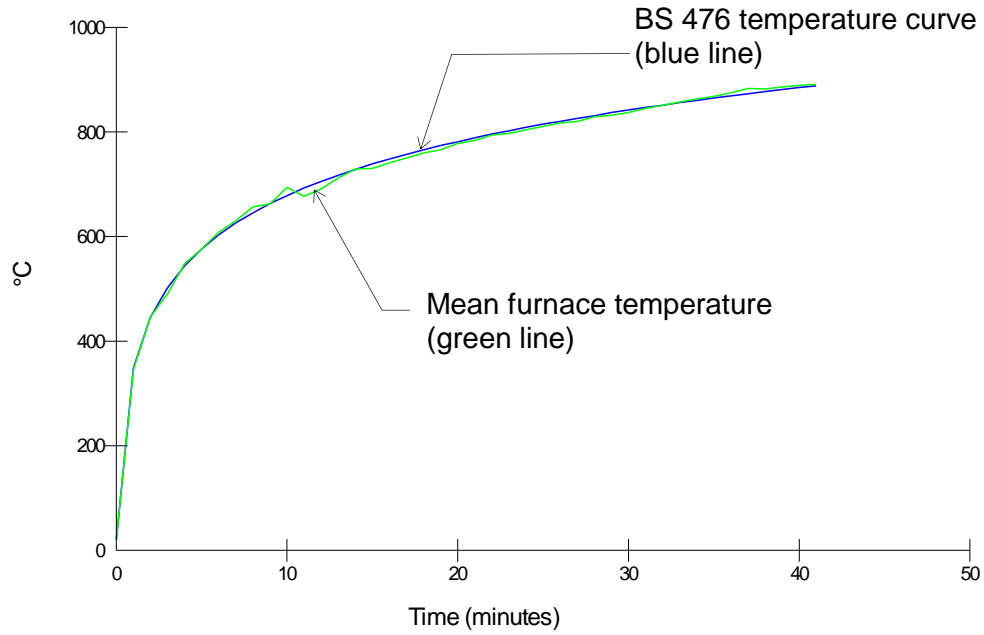

## 5.2 Unexposed Face Temperature Curves

### Doorset A

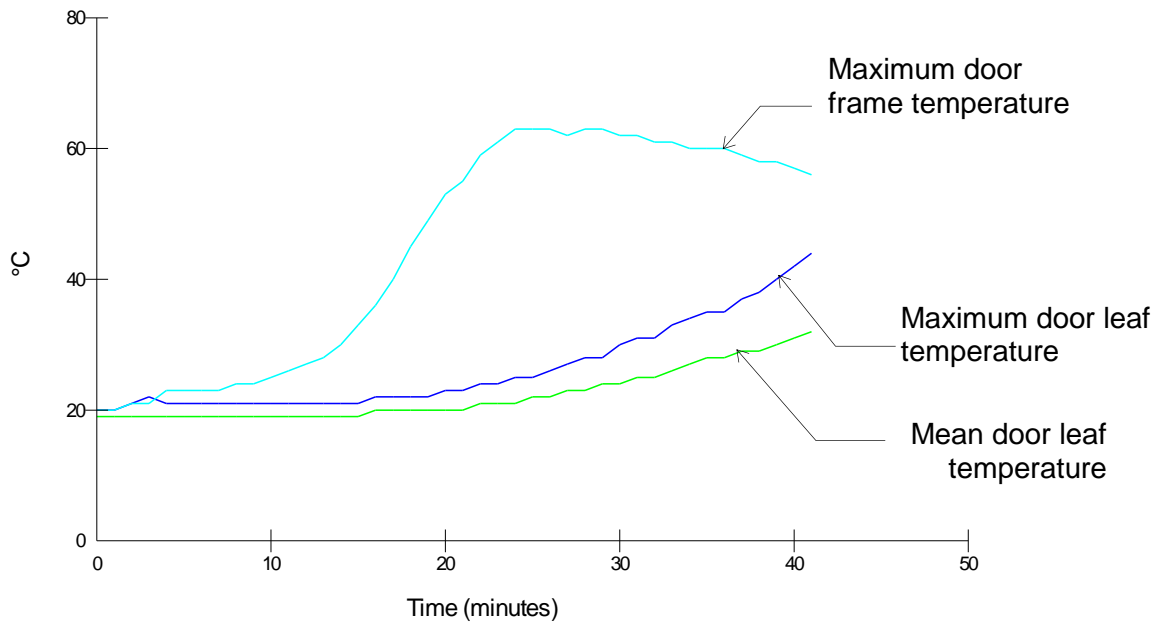

### Glazing

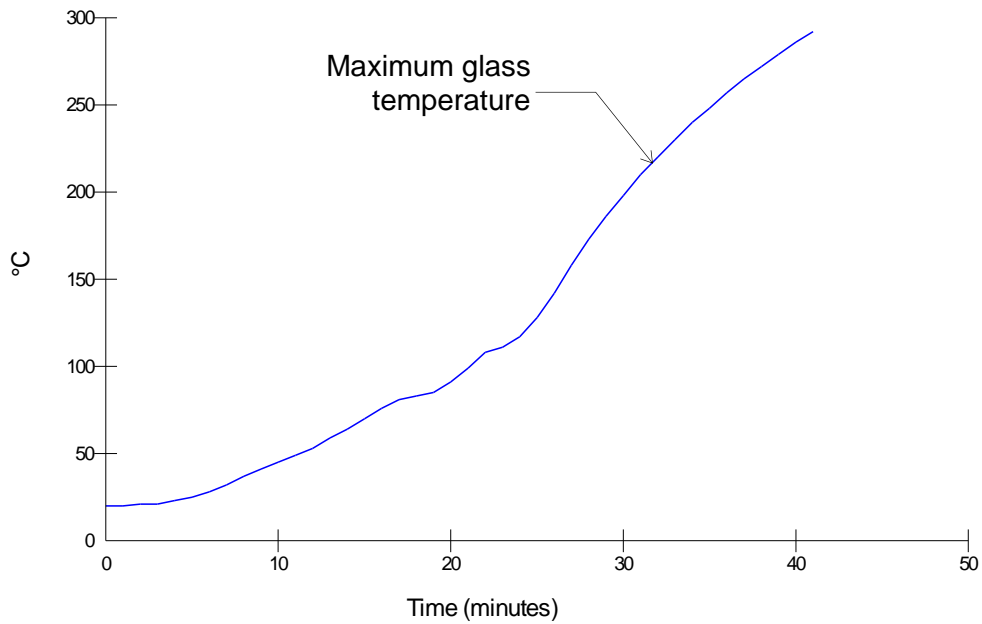

### Doorset B

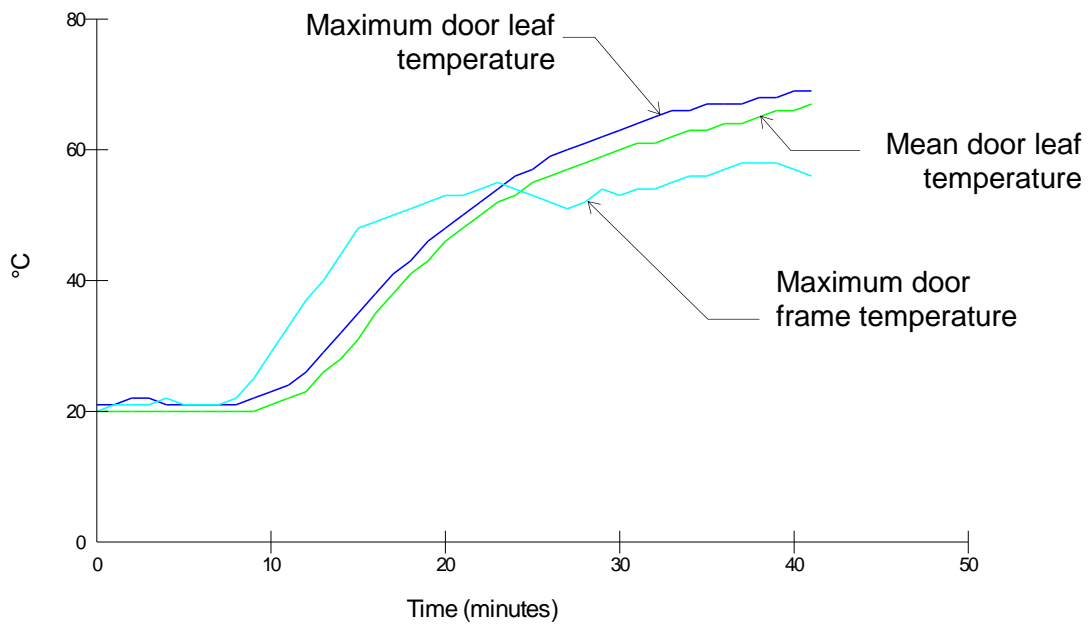

### Glazing

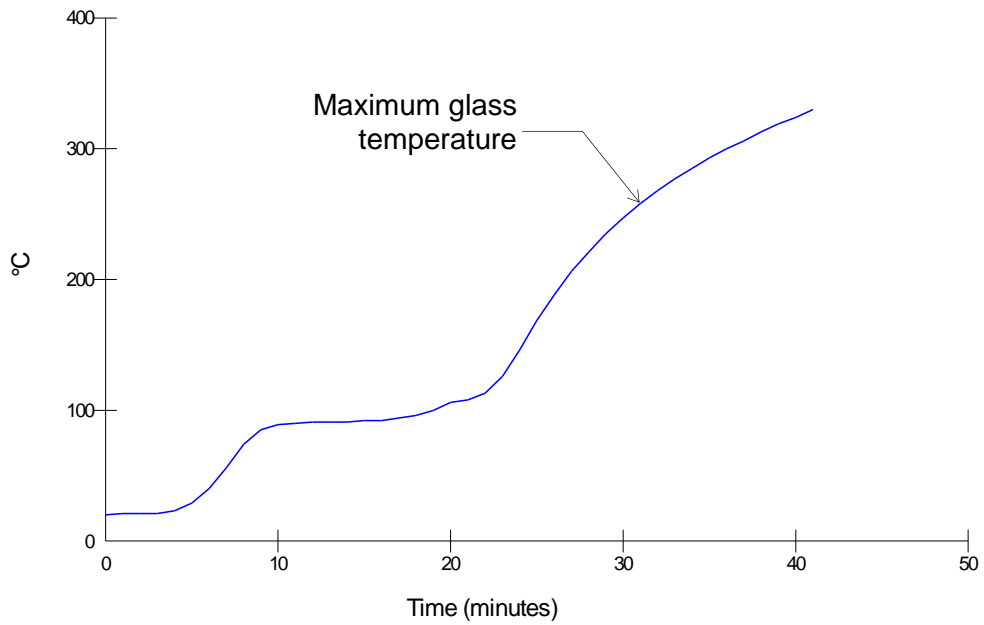

## Radiation

A medtherm heatflux radiometer was used to measure the radiation 1m away from each doorsets.

The results of the radiometer were recorded and are shown graphically below:

### Doorset A

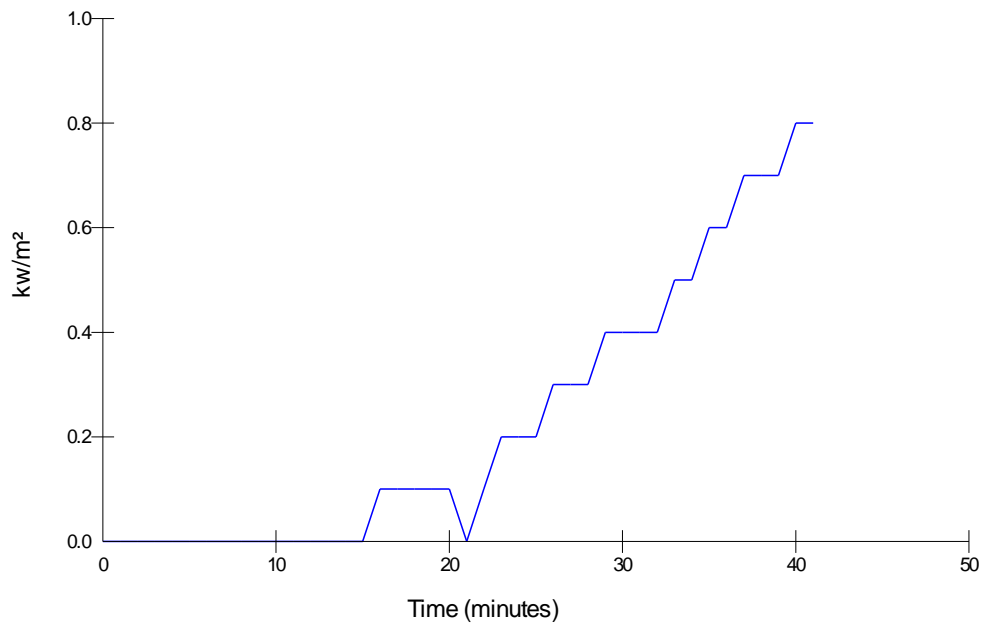

### Doorset B

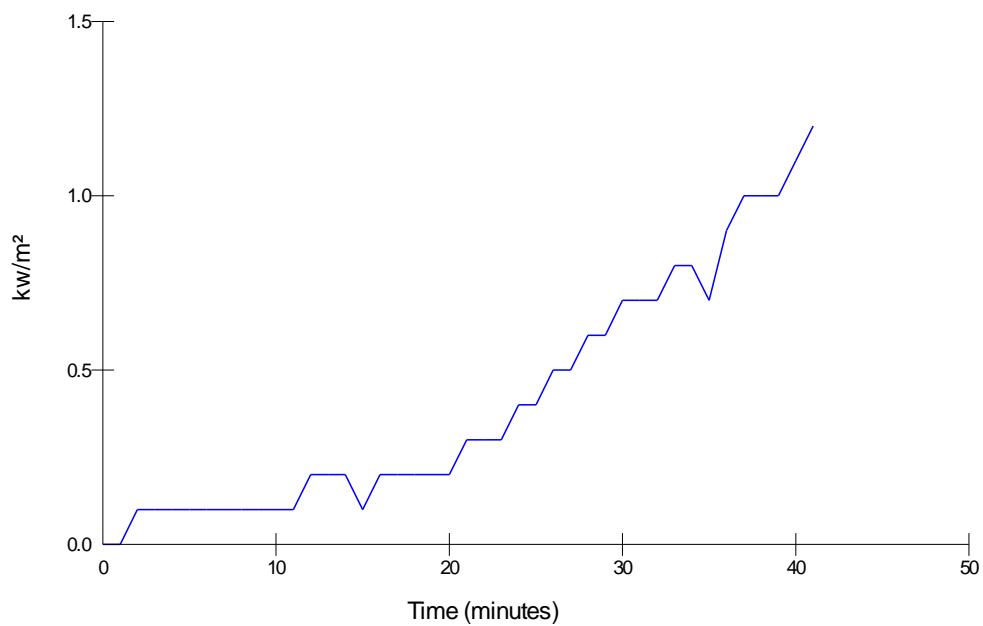

### 5.3 Door Distortion Data

The following tables show the distortion of the door in mm with an accuracy of  $\pm 1$ mm. A positive measurement indicates distortion towards the furnace. A negative measurement indicates distortion away from the furnace. J, K and L give vertical movement of the door, a negative reading indicates that the door has dropped.

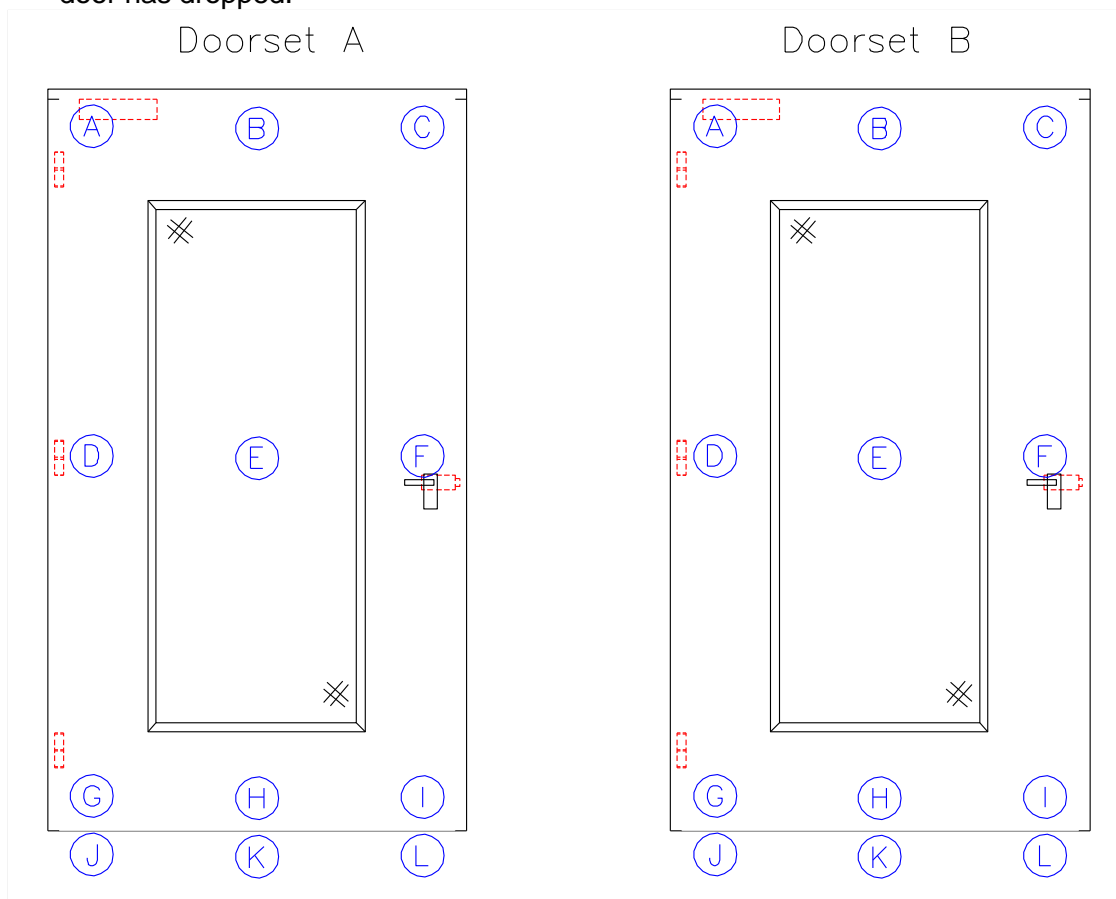

**Doorset A - leaf (hung on the left and opening in towards the furnace)**

Time	A	B	C	D	E	F	G	H	I	J	K	L
10	6	7	9	-7	-1	1	9	-6	2	-1	3	-2
20	6	1	11	-17	-1	2	11	-5	6	-1	-1	-3
30	6	9	12	-6	-2	12	11	-4	8	-3	-3	6

**Doorset B – left leaf (hung on the left and opening in towards the furnace)**

Time	A	B	C	D	E	F	G	H	I	J	K	L
10	3	0	4	1	1	-3	1	1	4	-1	0	-2
20	2	-1	5	1	4	-3	1	2	4	-2	-3	-3
30	6	-1	10	2	5	0	2	1	9	-3	-3	-3



#### 5.4 Door leaf to frame gaps

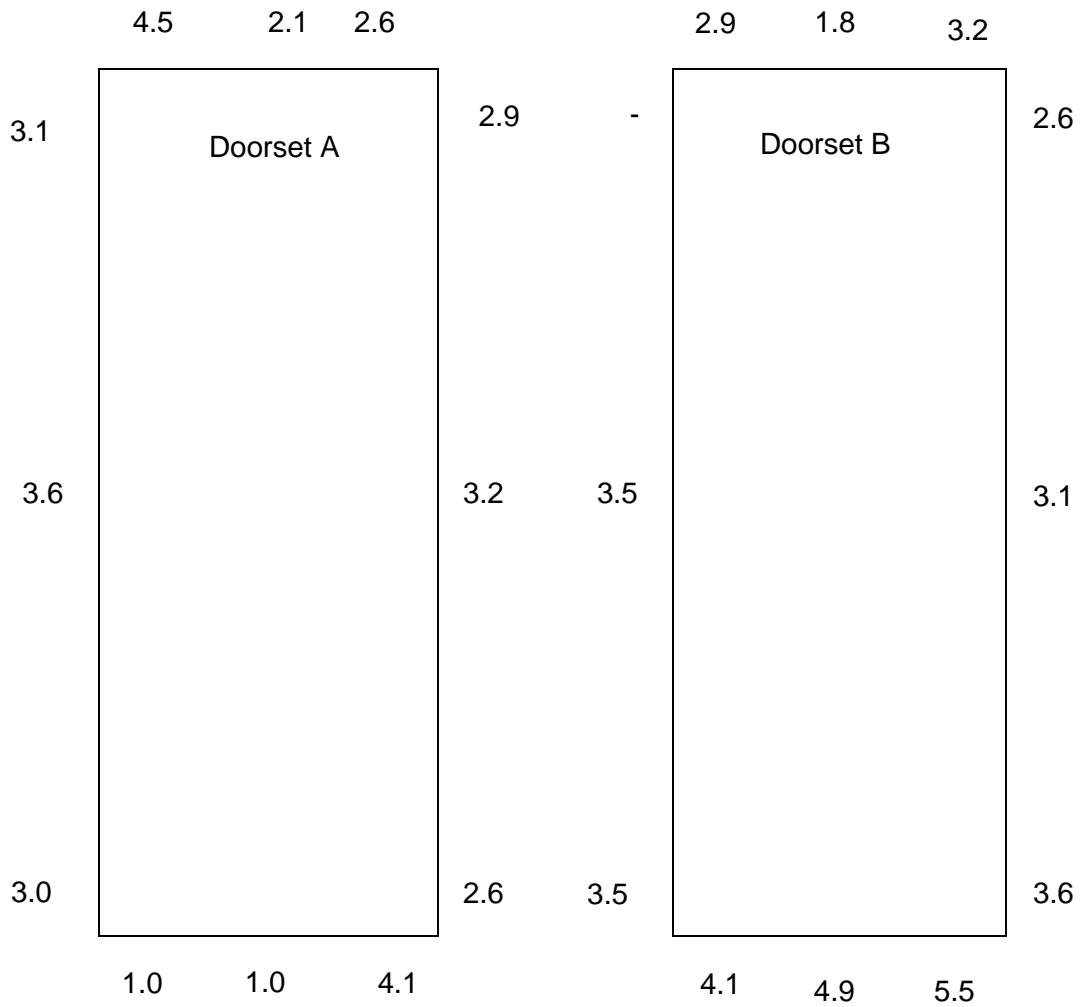

Gaps shown

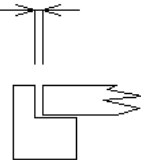

## 5.5 Observations

All comments relate to the unexposed face unless otherwise specified.

<b>Time (minutes)</b>	<b>Comments</b>
00:00	Test started
01:10	Doorset A, There is smoke issuing from the latch position.
02:12	Doorset B, There is smoke issuing from the latch position.
02:30	Doorset A, There is smoke issuing from the centre of the head and from the closing edge, 400mm below the latch position.
03:20	Doorset A, There is an increase in the amount of smoke issuing from the head and the closing edge.
03:30	Doorset B, There is an increase in the amount of smoke issuing from the top hanging corner, the top closing corner and the closing edge.
04:00	Doorsets A and B, There are cracks in the layer of glass on the exposed face of the sample, the intumescent reacts.
05:00	Doorset A, There is an increase in the amount of smoke issuing and discolouration at the closing edge.
07:00	Doorset A, There is discolouration at the centre of the head.
07:50	Doorset B, There is smoke issuing from the hanging edge and from the middle hinge position upwards.
08:00	Doorset A, There is smoke issuing from across the head.
10:00	Doorset A, There is discolouration at the latch position.
11:40	Doorset A, There is an increase in the amount of smoke issuing from the latch position.
14:00	Doorset A, There is an increase in the amount of smoke issuing from the top hanging corner.
14:20	Doorset B, There is an increase in the amount of smoke issuing from the top hanging corner.
15:00	Doorset A, The top third of the blind has moved to the closed position.
16:00	Doorset A, The top third of the blind has moved to the open position.
17:00	Doorset A, The blind is closed 1/2 of the way up.
17:50	Doorset B, The blind is open 1/2 of the way up.
18:15	Doorset A, The blind has moved 200mm up.

18:40	Doorset B, The blind between the glazing panels has fallen down.
20:45	Doorset A, The blind between the glazing panels has fallen down.
21:00	Doorset A, There is discolouration at the top hinge position.
22:00	Doorset B, There is discolouration at the top hanging corner and the top closing corner.
23:00	Doorset A, There is intermittent flaming at the bottom closing corner.
29:00	Doorset B, There is smoke issuing from the middle of the left glazing bead.
29:40	Doorset A, There is smoke issuing from the middle of the left glazing bead.
30:20	Doorset B, There is an increase in the amount of smoke issuing from the left glazing bead.
31:05	Doorset A, There is smoke issuing from the left glazing bead.
32:00	Doorset B, There is smoke issuing from the right glazing bead 600mm down.
33:45	Doorset A, There is an increase in the amount of smoke issuing from the middle of the left glazing bead.
34:00	Doorset A, There is discolouration above the glazing at the top right corner.
35:00	Doorset B, The plastic around the outer layer of glass is melting.
40.00	Test terminated.

## 5.6 Times to Failure

When was tested in accordance with BS 476: Part 22: 1987, Method 8, determination of fire resistance of uninsulated doorsets and shutter assemblies, the requirements of the standard were satisfied for the following periods:

	Doorset A	Doorset B
<b>Integrity</b>	<b>40 (forty) minutes *</b>	<b>40 (forty) minutes *</b>
<b>Insulation</b>	<b>0 (zero) minutes **</b>	<b>0 (zero) minutes **</b>

\* No failure at the termination of the test.

\*\* In accordance with Section 8.6.1 of BS 476: Part 22: 1987, the specimen has not been evaluated for insulation

Revision A – 12/03/2020 - Page 9 and 10, glazing spacer material changed from steel to aluminium at the request of the client.



## 6 Limitations

The results only relate to the behaviour of the element of construction under the particular conditions of test; they are not intended to be the sole criteria for assessing the potential fire performance of the element in use nor do they reflect the actual behaviour in fires.

The results of this test were obtained using the specimens provided for testing, and the door to frame gaps recorded in section 5.4 of this report. Further, where information in relation to the specimen has been provided to us but not verified by us, we have assumed that it is correct; and where comments above identify particular materials or substances comprised in the specimen those comments are based on information supplied to us and/or on general visual inspection undertaken during the process of testing of the sample, and in either case have not been verified by reference to materials testing or documentary evidence except as described above. The fire resistance performance of doors of this design may be different if any aspect of the design or construction differs from that tested. This includes, by way of example only, any difference as a result of (i) any deviation from the information supplied to us, or (ii) the employment of different door to frame gaps. The tested assembly was asymmetrical and was tested such that both door leaves opened in towards the heating conditions of the test. The test result may not be appropriate to situations where by the samples tested have been installed in a different configuration to that which they are tested.

The specification and interpretation of fire test methods are the subject of ongoing development and refinement. Changes in associated legislation may also occur. No assurance can be given that this test or its results will reflect current practice, and/or be consistent with prevailing legislative / regulatory requirements, at any time after the date of this report. Exova Warringtonfire will be able to offer the addressee of this report, at any time on request, a review of the procedures adopted for a particular test to ensure that they are consistent with current practices, and if required may endorse the test report. It is strongly recommended that, at the latest, such a review be sought at intervals of no more than five years.

**This report may only be reproduced in full. Extracts or abridgements of reports shall not be published without permission of Warringtonfire. All work and services carried out by Warringtonfire Testing and Certification Limited are subject to, and conducted in accordance with, the Standard Terms and Conditions of Warringtonfire Testing and Certification Limited, which are available at <https://www.element.com/terms/terms-and-conditions> or upon request.**

	Written and Checked by:	Authorised by:
Signature:		
Name:	John Jones	Adam Scott
Title:	Technical Officer	Laboratory Manager
Date of issue:	16/03/2020	16/03/2020

## Photographs

Intumescent interruptions by hardware

Around hinge blade – doorset A



Around hinge blade – doorset B



Around latch keep – doorset A



Around latch keep – doorset B



At start of test



After 10 minutes



After 20 minutes



At 30 minutes



At 40 minutes



Exposed face, post test





**Appendix – figures 1 to 4**



Doorset A

Doorset B

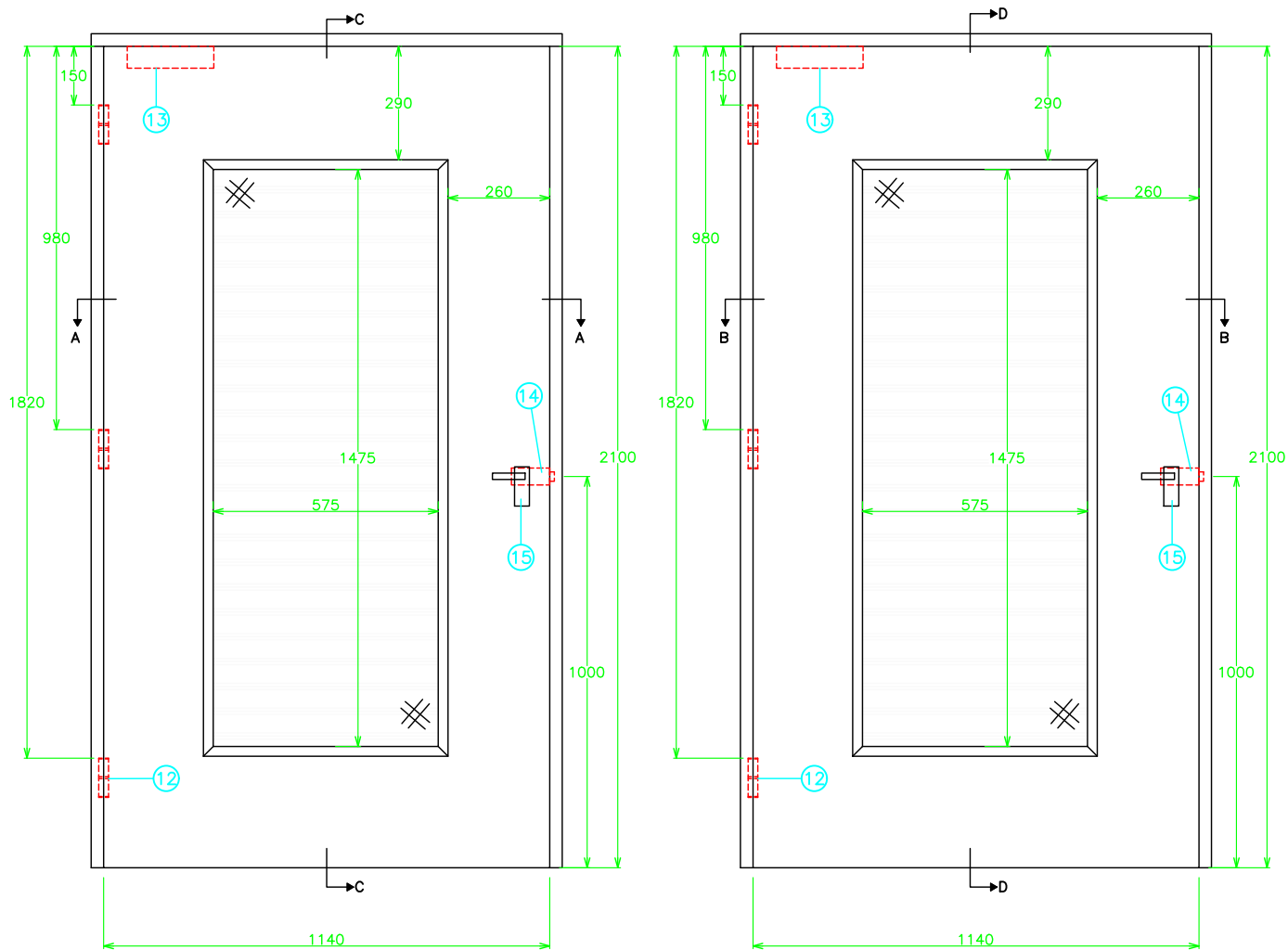

**warringtonfire**  
Proud to be part of element

Warringtonfire, Stocking Lane,  
Hughenden Valley, High Wycombe,  
Buckinghamshire, HP14 4ND, UK.  
Tel: +44 (0)1494 569750

Title Unexposed face elevation  
showing hardware positions  
(All dimensions in mm)

Date Drawn 01/10/18	Drawn By ARD	Scale NTS
------------------------	-----------------	--------------

Project No. WF 403484 REV A	Appendix
--------------------------------	----------

Section A-A

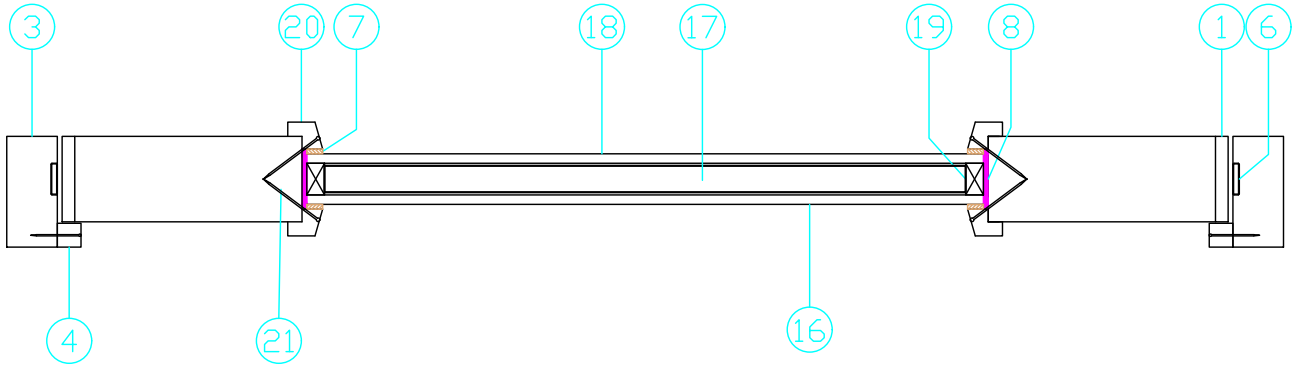

Section B-B

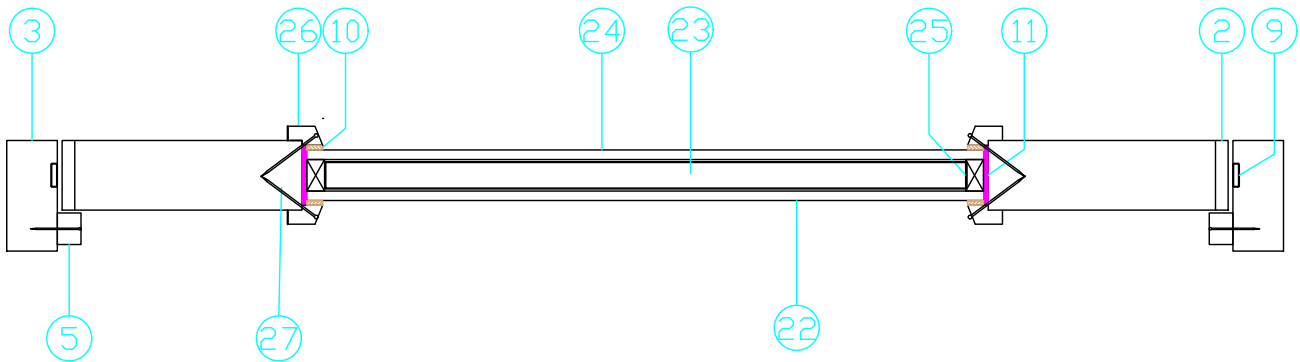

Warringtonfire, Stocking Lane,  
 Hughenden Valley, High Wycombe,  
 Buckinghamshire, HP14 4ND, UK.  
 Tel: +44 (0)1494 569750

Title  
 Horizontal cross-sections  
 (All dimensions in mm)

Date Drawn 01/10/18	Drawn By ARD	Scale NTS
Project No. WF 403484 Rev A		Appendix

Section C-C

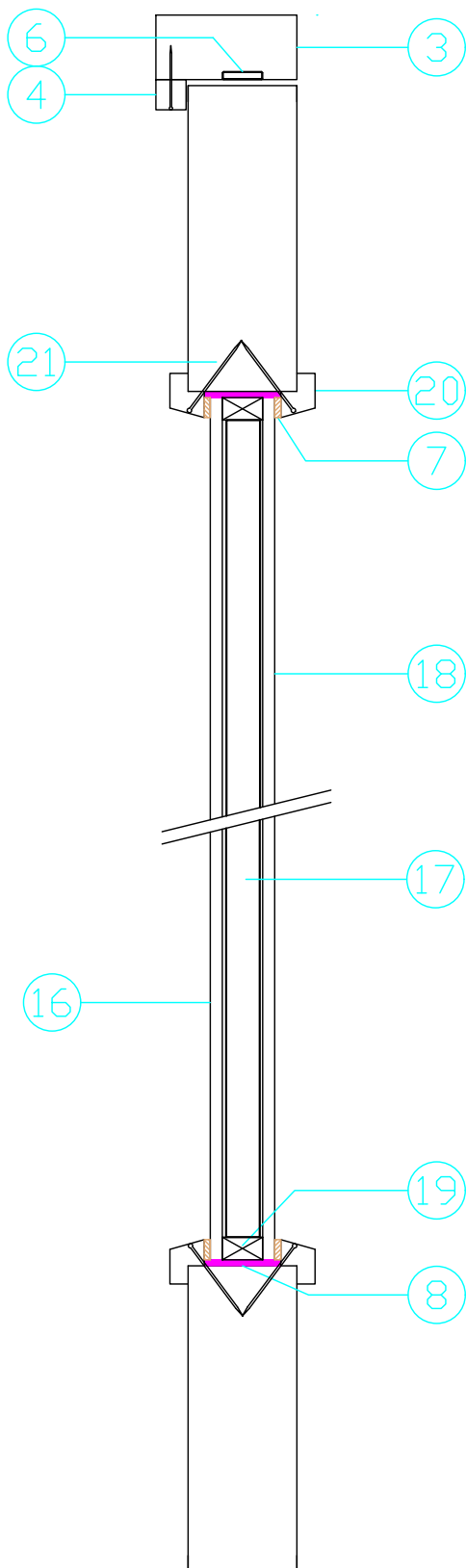

Section D-D

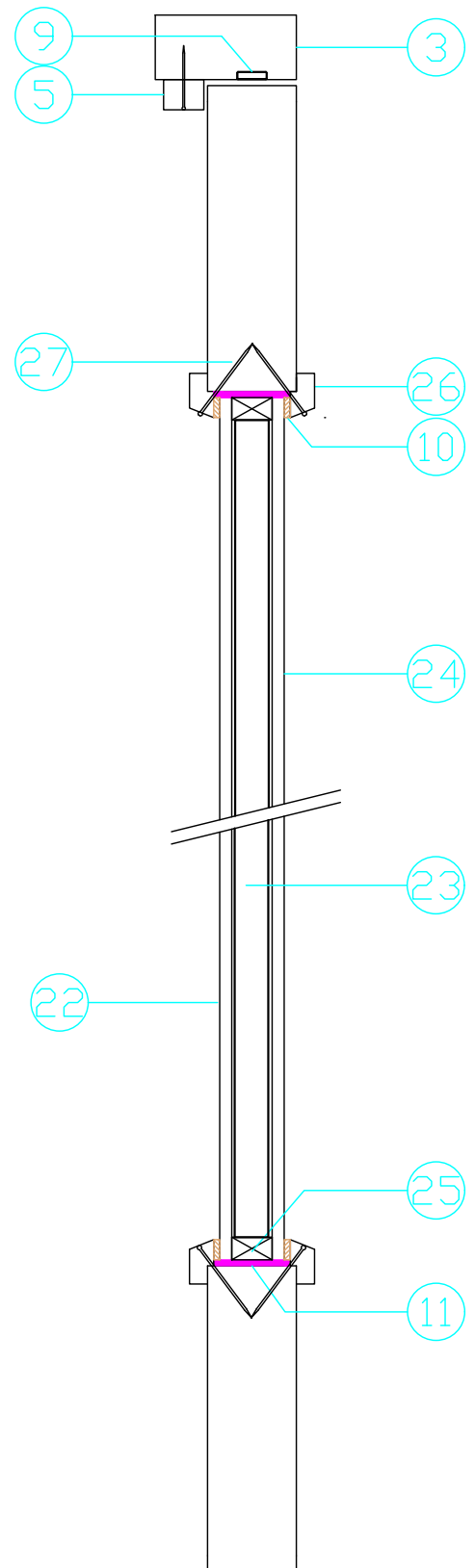

Warringtonfire, Stocking Lane,  
 Hughenden Valley, High Wycombe,  
 Buckinghamshire, HP14 4ND, UK.  
 Tel: +44 (0)1494 569750

Title

Vertical cross-sections  
 (All dimensions in mm)

Date Drawn

01/10/18

Drawn By

ARD

Scale

NTS

Project No.

WF 403484 Rev A

Appendix

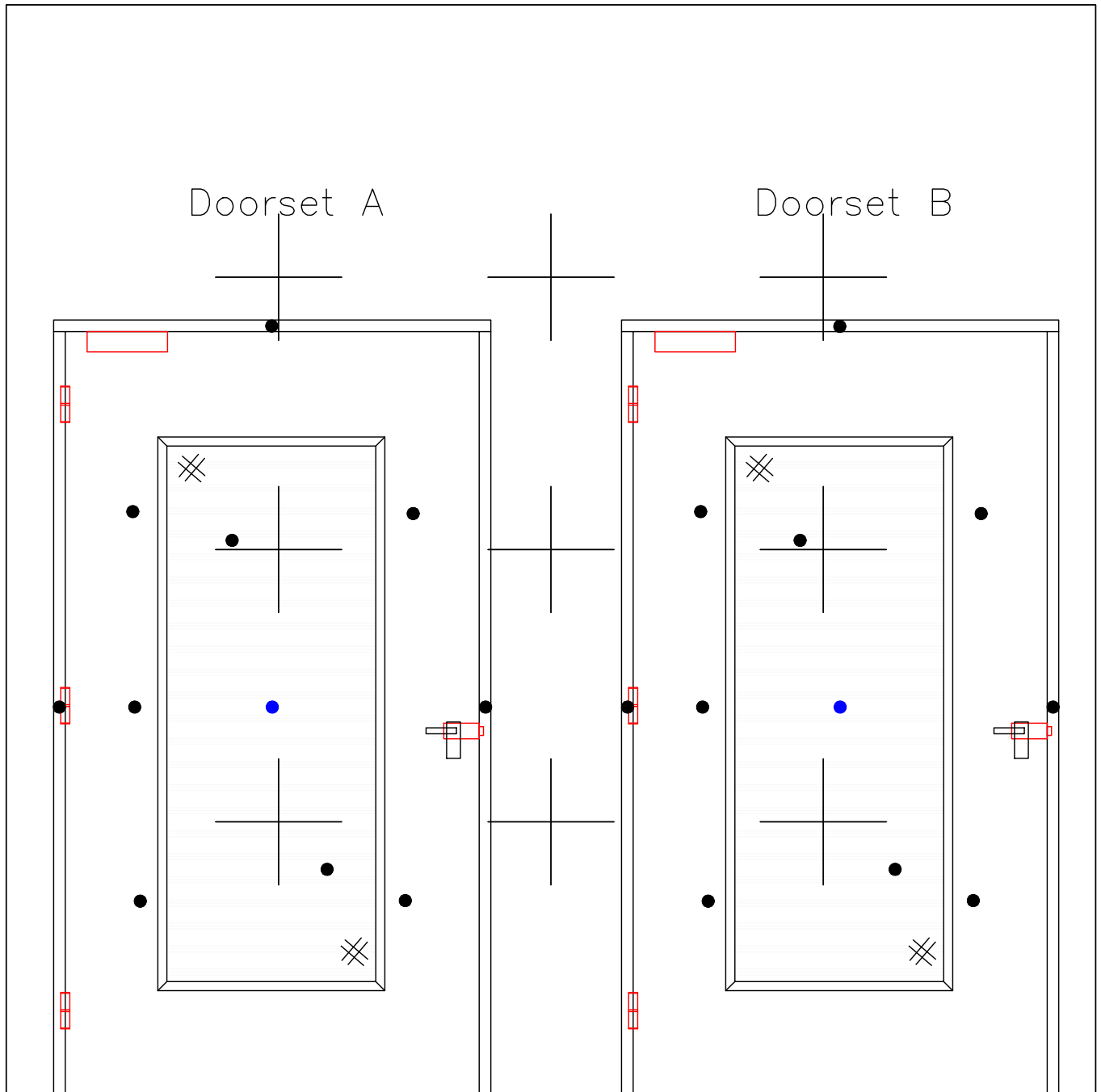

- ⊕ : Furnace Thermocouples
- : Unexposed Face Thermocouples
- : Radiometer

Viewed From Unexposed Face



Warringtonfire, Stocking Lane,  
 Hughenden Valley, High Wycombe,  
 Buckinghamshire, HP14 4ND, UK.  
 Tel: +44 (0)1494 569750

Title Thermocouple positions

(All dimensions in mm)

Date Drawn 01/10/18	Drawn By ARD	Scale NTS
Project No. WF 403484 Rev A		Appendix